

# KENTER SHACKLE

センターシャックル (JIS F 3303-2010)

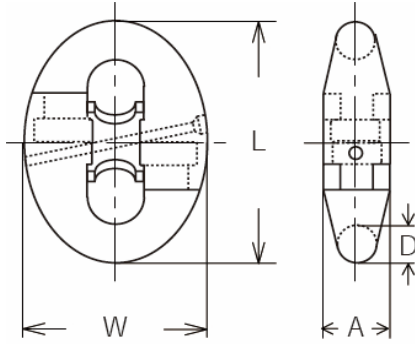

呼び径 mm	径 (Diameter)		外長 (Length)			外幅 (Width)			A
	標準	最大	最小	標準	最大	最小	標準	最大	
16	16.0	16.8	93.6	96.0	98.4	65.5	67.2	68.9	24.3
19	19.0	20.0	111.2	114.0	116.9	77.8	79.8	81.8	28.9
20.5	20.5	21.5	119.9	123.0	126.1	83.9	86.1	88.3	31.2
22	22.0	23.1	128.7	132.0	135.3	90.1	92.4	94.7	33.4
24	24.0	25.2	140.4	144.0	147.6	98.3	100.8	103.3	36.5
25	25.0	26.3	146.3	150.0	153.8	102.4	105.0	107.6	38.0
26	26.0	27.3	152.1	156.0	159.9	106.5	109.2	111.9	39.5
28	28.0	29.4	163.8	168.0	172.2	114.7	117.6	120.5	42.6
30	30.0	31.5	175.5	180.0	184.5	122.9	126.0	129.2	45.6
32	32.0	33.6	187.2	192.0	196.8	131.0	134.4	137.8	48.6
34	34.0	35.7	198.9	204.0	209.1	139.2	142.8	146.4	51.7
36	36.0	37.8	210.6	216.0	221.4	147.4	151.2	155.0	54.7
38	38.0	39.9	222.3	228.0	233.7	155.6	159.6	163.6	57.8
40	40.0	42.0	234.0	240.0	246.0	163.8	168.0	172.2	60.8
42	42.0	44.1	245.7	252.0	258.3	172.0	176.4	180.8	63.8
44	44.0	46.2	257.4	264.0	270.6	180.2	184.8	189.4	66.9
46	46.0	48.3	269.1	276.0	282.9	188.4	193.2	198.0	69.9
48	48.0	50.4	280.8	288.0	295.2	196.6	201.6	206.6	73.0
50	50.0	52.5	292.5	300.0	307.5	204.8	210.0	215.3	76.0
52	52.0	54.6	304.2	312.0	319.8	212.9	218.4	223.9	79.0
54	54.0	56.7	315.9	324.0	332.1	221.1	226.8	232.5	82.1
56	56.0	58.8	327.6	336.0	344.4	229.3	235.2	241.1	85.1
58	58.0	60.9	339.3	348.0	356.7	237.5	243.6	249.7	88.2
60	60.0	63.0	351.0	360.0	369.0	245.7	252.0	258.3	91.2
62	62.0	65.1	362.7	372.0	381.3	253.9	260.4	266.9	94.2
64	64.0	67.2	374.4	384.0	393.6	262.1	268.8	275.5	97.3
66	66.0	69.3	386.1	396.0	405.9	270.3	277.2	284.1	100.3
68	68.0	71.4	397.8	408.0	418.2	278.5	285.6	292.7	103.4
70	70.0	73.5	409.5	420.0	430.5	286.7	294.0	301.4	106.4
73	73.0	76.7	427.1	438.0	449.0	298.9	306.6	314.3	111.0
76	76.0	79.8	444.6	456.0	467.4	311.2	319.2	327.2	115.5